

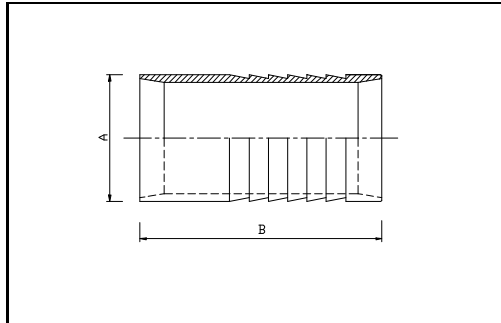

## 10 SWG HOSE TAILS

### 10 SWG HOSE TAIL WELD ENDED



	A	B	W/T
1"	25.4	75.0	3.0
1 1/2"	38.1	75.0	3.0
2"	50.8	75.0	3.0
2 1/2"	63.5	75.0	3.0
3"	76.2	75.0	3.0
4"	101.6	100.0	3.0

### 10 SWG RJT HOSE LINER

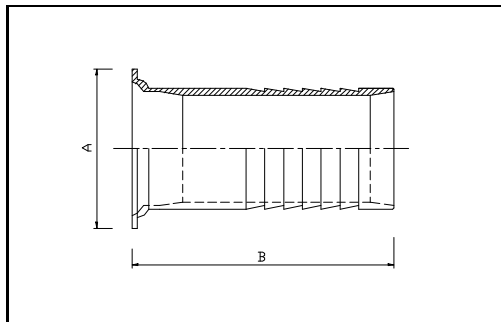

	A	B	W/T
1"	41.0	87.0	3.0
1 1/2"	54.0	87.0	3.0
2"	66.0	87.0	3.0
2 1/2"	79.0	87.0	3.0
3"	92.0	87.0	3.0
4"	117.0	112.0	3.0

### 10 SWG TRI-CLAMP HOSE TAIL

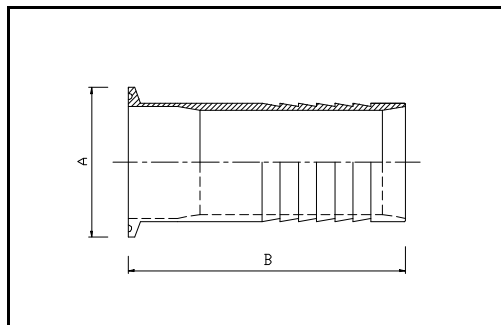

	A	B	W/T
1"	50.5	96.0	3.0
1 1/2"	50.5	96.0	3.0
2"	64.0	96.0	3.0
2 1/2"	77.5	96.0	3.0
3"	91.0	96.0	3.0
4"	119.0	121.0	3.0

*Hose tails can be hygienically fabricated with any fittings required , RJT , IDF , SMS , Din , ILC , BSP etc. all welds removed OD / ID .*

*Also can be fabricated to 90 bends , Tees , Y pieces etc.*